

SINGER
30215,30518,342,345

LIST OF PARTS

Sewing Machine Models

30215

30518

342

345

by **SINGER®**

From the library of: Diamond Needle Corp



A Publication of Product Support
International Group Engineering

PartNo. 317161- 069A

Printed in Taiwan

SINGER Is a Registered Trademark of The Singer Company Limited
Copyright 1995, Singer Sewing Machine Company

All rights reserved throughout the world

INDEX

PAGE NO.	SUBASSEMBLY
1, 2	ATTACHMENT SET
3, 4	COVERS AND ADD ONS
5, 6	ARM SHAFT DRIVE SYSTEM
7, 8	HAND WHEEL
9, 10	HEAD END
11, 12	HOOK AND FEED SYSTEM
13, 14	DEMAND RESPONSIVE NEEDLE TENSION SYSTEM
15, 20	PATTERN, STITCH LENGTH CONTROL & CAM CONTROLLED FEED
21, 24	ELECTRICAL EQUIPMENT

ATTACHMENT SET
 MODEL: 302/305/342/345

REF. PART NO.	PART NO.	DESCRIPTION	3	3	3	3
			0	0	4	4
			2	5	2	5
1	316010-001	ATTACHMENT SET	X	X	X	X
2	316004	FEED COVER PLATE	X	X	X	X
3	353364	NEEDLE PACK	X	X	X	X
4	81348-451	SHUTTLE BOBBIN	X	X	X	X
4	2518	BOBBIN (METAL), ALTERNATE (AMMAN ONLY)	X	X	X	X
5	316002	SPECIAL PURPOSE FOOT	X	X	X	X
6	316007	ZIPPER FOOT	X	X	X	X

ATTACHMENT SETS

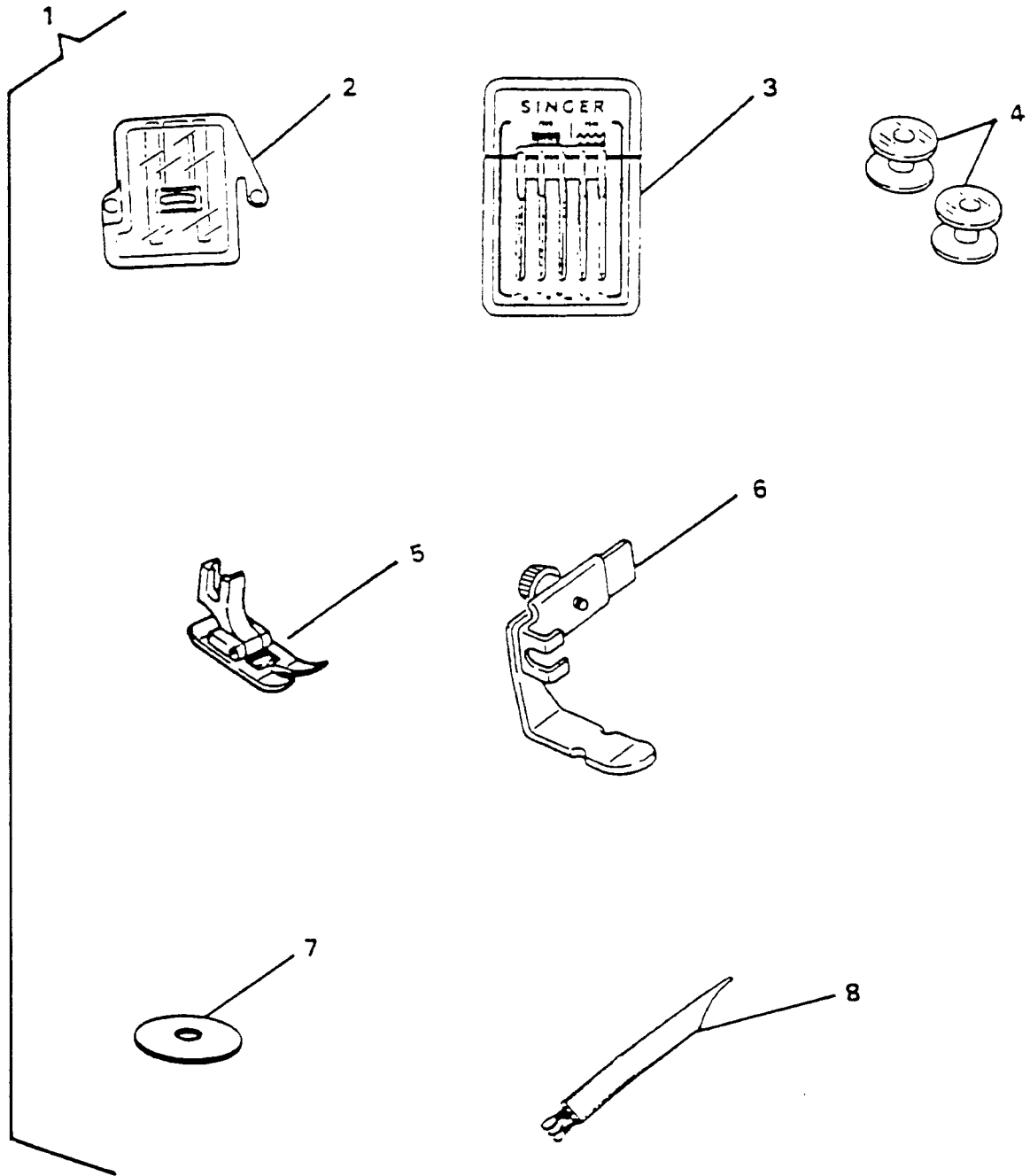

From the library of: Diamond Needle Corp

COVERS AND ADD ONS

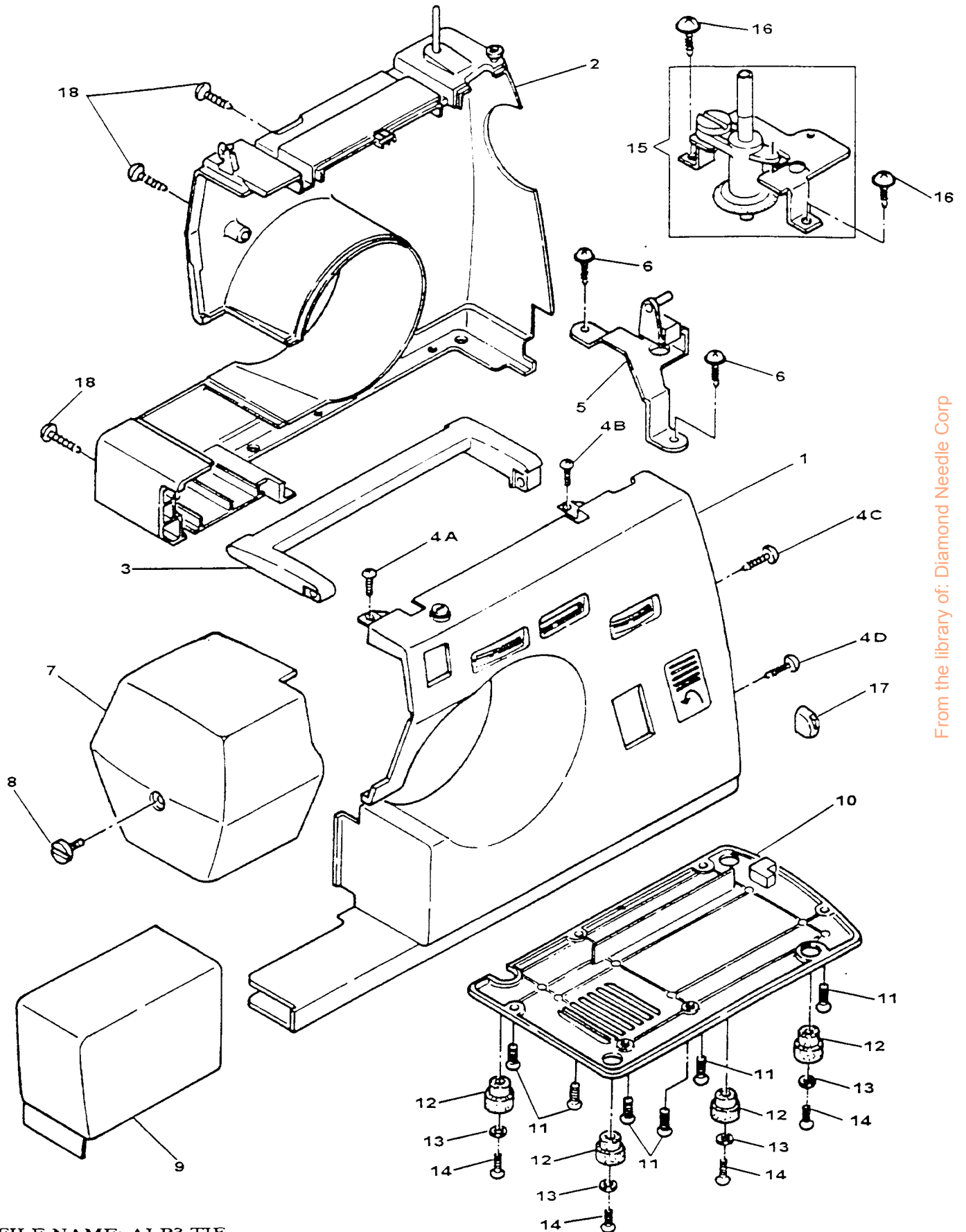

From the library of: Diamond Needle Corp

ADD AND COVERS ON
MODEL: 302/305

REF. NO.	PART NO.	DESCRIPTION	3	3
			0	0
			2	5
1	316011-001	FRONT COVER ASSEMBLY (MODEL 305)		X
1	316011-002	FRONT COVER ASSEMBLY (MODEL 302)		X
2	316061-001	REAR COVER ASSEMBLY	X	X
3	316211-451	MACHINE HANDLE	X	X
4A	544212-006	SCREW, FRONT COVER MOUNTING	X	X
4B	316314-451	SCREW, FRONT COVER MOUNTING	X	X
4C	113455-001	SCREW, FRONT COVER MOUNTING	X	X
4D	113455-017	SCREW, FRONT COVER MOUNTING	X	X
5	316209-451	MACHINE HANDLE BRACKET WITH SPRING	X	X
6	113455-001	SCREW, MACHINE HANDLE BRACKET	X	X
7	316293-001	FACE PLATE COMPLETE	X	X
8	113521-451	SCREW, FACE PLATE MOUNTING	X	X
9	316025-900	EXTENSION TABLE	X	X
10	316023-900	BASE COVER	X	X
11	113442-003	SCREW, BASE COVER MOUNTING	X	X
12	316104-001	FRAME EXTENSION CUSHION (RUBBER)	X	X
13	316062	WASHER, FRAME EXTENSION CUSHION	X	X
14	113422-004	SCREW, FRAME EXTENSION CUSHION MOUNTING	X	X
15	316208-001	BOBBIN WINDER SUB-ASSEMBLY	X	X
16	113455-002	SCREW, BOBBIN WINDER MOUNTING BRACKET	X	X
17	316089-451	KNOB, BIGHT AMPLITUDE CONTROL LEVER & NEEDLE POSITION CONTROL LEVER	X	X
18	113455-001	SCREW, REAR COVER ASSEMBLY MOUNTING	X	X

ADD AND COVERS ON
MODEL: 342/345

REF. PART NO.	PART NO.	DESCRIPTION		
			3	3
			4	4
			2	5
1	316210-001	FRONT COVER ASSEMBLY		X
1	316210-002	FRONT COVER ASSEMBLY		X
2	316212-001	REAR COVER ASSEMBLY	X	X
3	316092-451	MACHINE HANDLE	X	X
4A	544212-006	SCREW, FRONT COVER MOUNTING	X	X
4B	316314-451	SCREW, FRONT COVER MOUNTING	X	X
4C	113455-001	SCREW, FRONT COVER MOUNTING	X	X
4D	113455-017	SCREW, FRONT COVER MOUNTING	X	X
5	316093-451	MACHINE HANDLE BRACKET WITH SPRING	X	X
6	113455-001	SCREW, MACHINE HANDLE BRACKET	X	X
7	316294-001	FACE PLATE COMPLETE	X	X
8	113521-451	SCREW, FACE PLATE MOUNTING	X	X
9	316101-451	EXTENSION TABLE	X	X
10	316103-451	BASE COVER	X	X
11	113442-003	SCREW, BASE COVER MOUNTING	X	X
12	316104-001	FRAME EXTENSION CUSHION (RUBBER)	X	X
13	316062	WASHER, FRAME EXTENSION CUSHION	X	X
14	113422-004	SCREW, FRAME EXTENSION CUSHION MOUNTING	X	X
15	316208-001	BOBBIN WINDER SUB-ASSEMBLY	X	X
16	113455-002	SCREW, BOBBIN WINDER MOUNTING BRACKET	X	X
17	316089-451	KNOB, BIGHT AMPLITUDE CONTROL LEVER & NEEDLE POSITION CONTROL LEVER	X	X
18	113455-001	SCREW, REAR COVER ASSEMBLY MOUNTING	X	X

COVERS AND ADD ONS

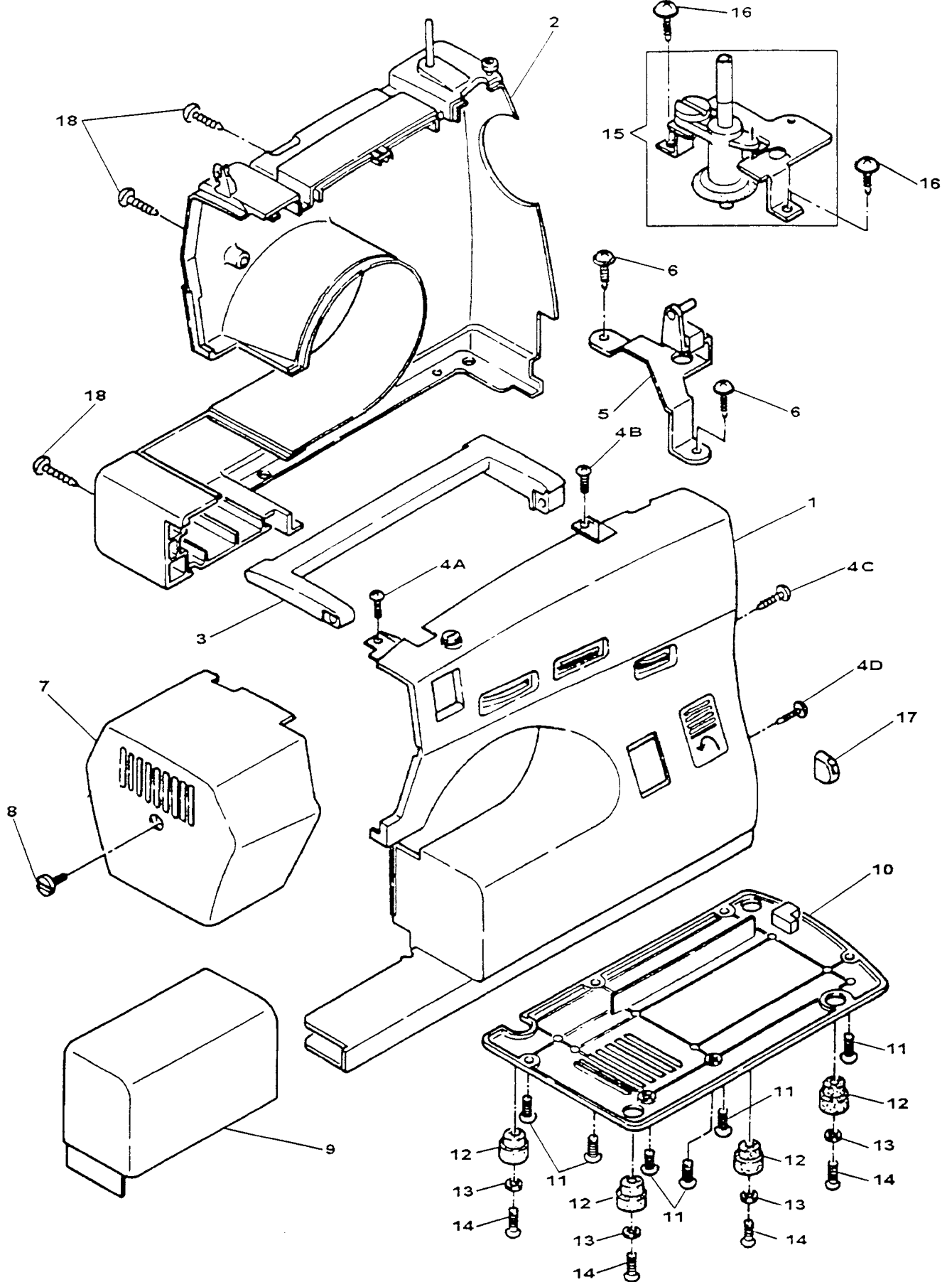

From the library of: Diamond Needle Corp

ARM SHAFT DIRVE SYSTEM

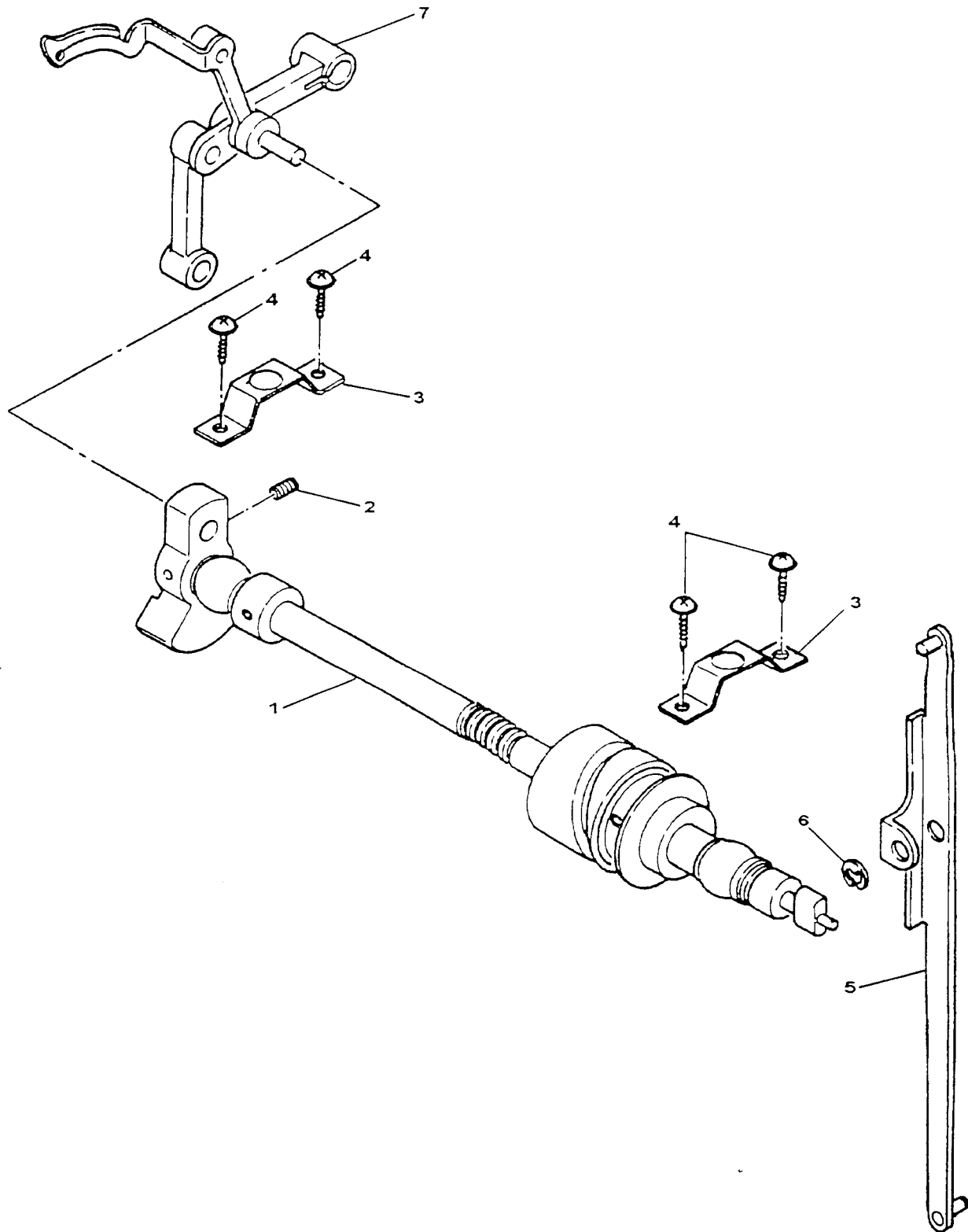

ARM SHAFT DRIVE SYSTEM
 MODEL: 302/305/342/345

REF. NO.	PART NO.	DESCRIPTION	3	3	3	3
			0	0	4	4
			2	5	2	5
1	316056-001	ARM SHAFT ASSEMBLY	X	X	X	X
2	113488-451	SCREW, THREAD TAKE-UP CRANK	X	X	X	X
3	316144	ARM SHAFT BUSHING CLAMP	X	X	X	X
4	113455-001	SCREW, ARM SHAFT BUSHING CLAMP MOUNTING	X	X	X	X
5	316031	RACK DRIVE LINK ASSEMBLY	X	X	X	X
6	316207-006	RING, RACK DRIVE LINK RETAINING	X	X	X	X
7	316286-001	THREAD TAKE-UP LEVER ASSEMBLY			X	X
7	316286-002	THREAD TAKE-UP LEVER ASSEMBLY	X	X		

HAND WHEEL
MODEL: 302/305/342/345

REF. PART NO.	DESCRIPTION	3	3	3	3
		0	0	4	4
		2	5	2	5
1	316070-001 HAND WHEEL CLUTCH PLATE ASSEMBLY	X	X	X	X
2	312628-001 MOTOR BELT	X	X	X	X
3	316065-451 HAND WHEEL	X	X	X	X
4	316207-010 HAND WHEEL RETAINING RING	X	X	X	X

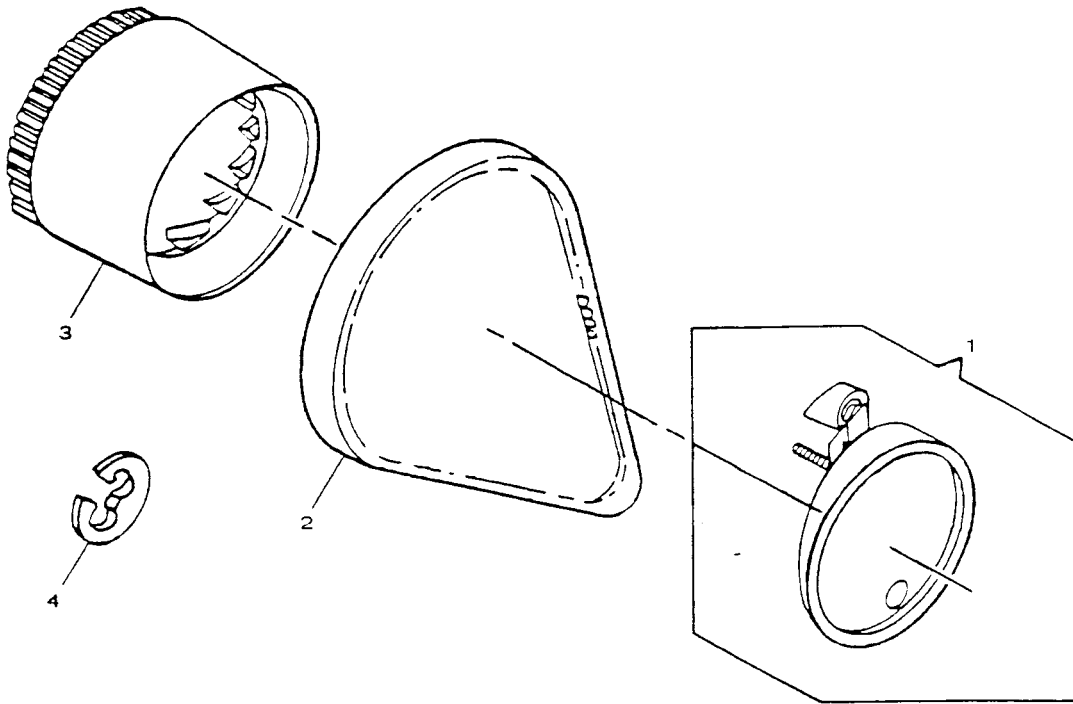

HEAD END

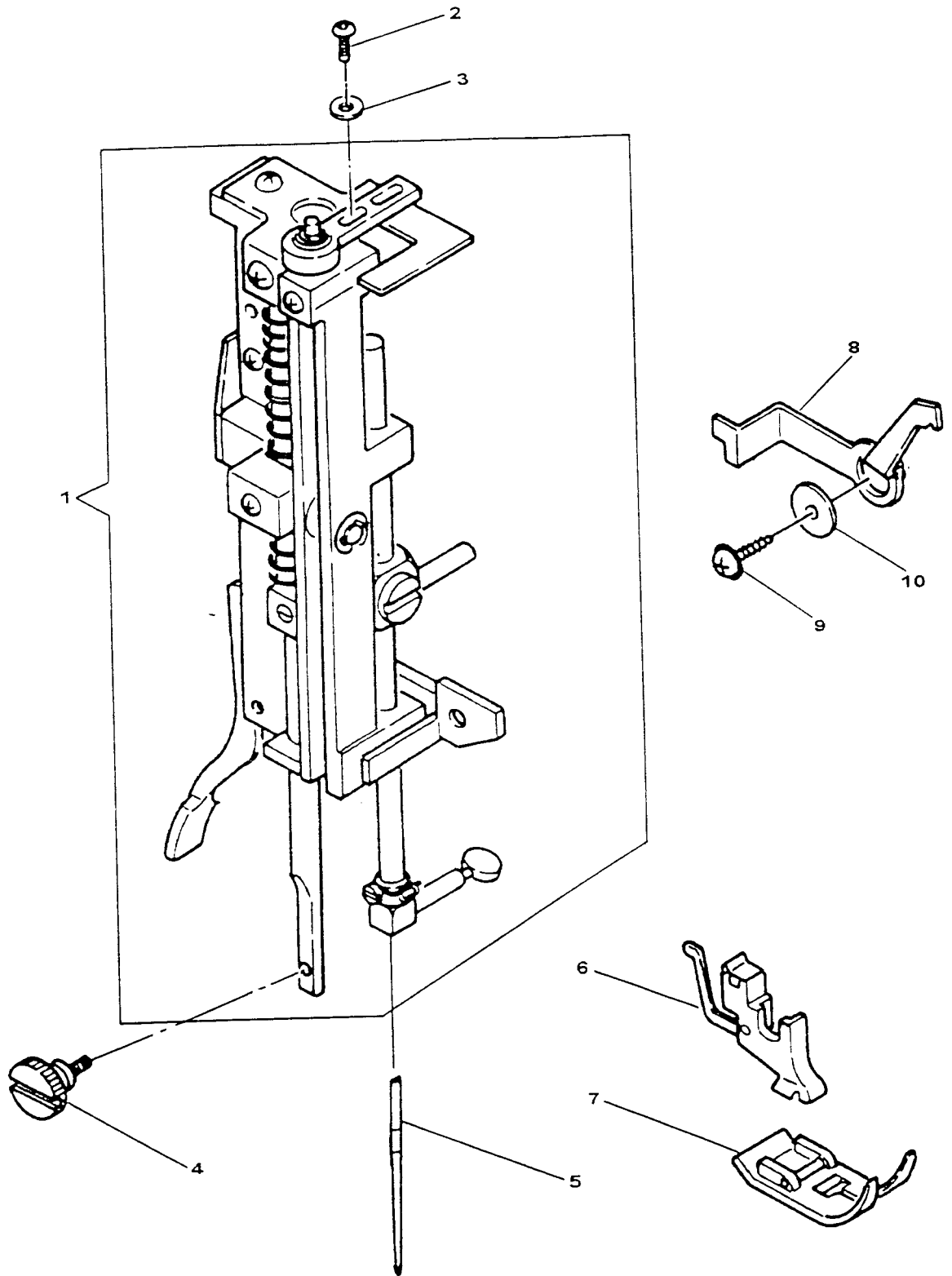

From the library of: Diamond Needle Corp

HEAD END
 MODEL: 302/305/342/345

REF. NO.	PART NO.	DESCRIPTION	3	3	3	3
			0	0	4	4
			2	5	2	5
1	316204-001	HEAD END MODULE	X	X	X	X
2	113408-001	NEEDLE BAR DRIVING ARM BALL JOINT SCREW	X	X	X	X
3	931929-004	WASHER, NEEDLE BAR DRIVING ARM BALL JOINT SCREW	X	X	X	X
4	113531-451	SCREW, PRESSER FOOT THUMB	X	X	X	X
5	N2020-14	NEEDLE (#14)	X	X	X	X
6	316008	PRESSER FOOT HOLDER	X	X	X	X
7	316001	GENERAL PURPOSE PRESSER FOOT	X	X	X	X
8	316147	THREAD TENSION RELEASE LEVER	X	X	X	X
9	113455-003	SCREW, THREAD TENSION RELEASE LEVER MOUNTING	X	X	X	X
10	314041-451	WASHER, THREAD TENSION RELEASE LEVER MOUNTING SCREW	X	X	X	X

HOOK AND FEED SYSTEM
MODEL: 302/305/342/345

REF. PART NO.	PART NO.	DESCRIPTION				
						3 3 3 3
						0 0 4 4
						2 5 2 5
1	316108	NEEDLE PLATE ASSEMBLY				
2	316349	SHUTTLE RACE FRAME ASSEMBLY				X X X X
3	316332	FEED LIFTING CAM				X X X X
4	354591-452	SCREW, FEED LIFTING CAM				X X X X
5	316334	WASHER, SHUTTLE DRIVER SHAFT ADJUSTING COLLAR				X X X X
6	314013-451	WASHER, SHUTTLE RACE FRAME ASSEMBLY				X X X X
7	113455-004	SCREW, SHUTTLE RACE FRAME ASSEMBLY				X X X X
8	316335	SHUTTLE DRIVER ASSEMBLY				X X X X
11	316345	SHUTTLE BODY				X X X X
12	402784	SHUTTLE BOBBIN CASE ASSEMBLY				X X X X
13	316112-001	SHUTTLE RACE GATE ASSEMBLY				X X X X
14	81348-451	BOBBIN				X X X X
15	316186	FEED REGULATOR DRIVING SHAFT ASSEMBLY				X X X X
16	316231	FEED REGULATOR DRIVING SHAFT BUSHING CLAMP				X X X X
17	113455-003	SCREW, FEED REGULATOR DRIVING SHAFT BUSHING CLAMP				X X X X
18	316107	FEED DOG				X X X X
19	316029-451	SCREW, FEED DOG MOUNTING				X X X X
20	316130	FEED LEVER WITH PLASTIC INSERT				X X X X
21	316138	FEED LEVER ECCENTRIC BUSHING				X X X X
22	316132	FEED LEVER STUD				X X X X
23	316083	FEED REGULATOR SHAFT SUPPORTING BRACKET				X X X X
24	113455-003	SCREW, FEED REGULATOR SHAFT SUPPORTING BRACKET				X X X X
25	316192	STITCH LENGTH CONTROL CRANK				X X X X
26	113523-451	SCREW, STITCH LENGTH CONTROL CRANK				X X X X

HOOK AND FEED SYSTEM

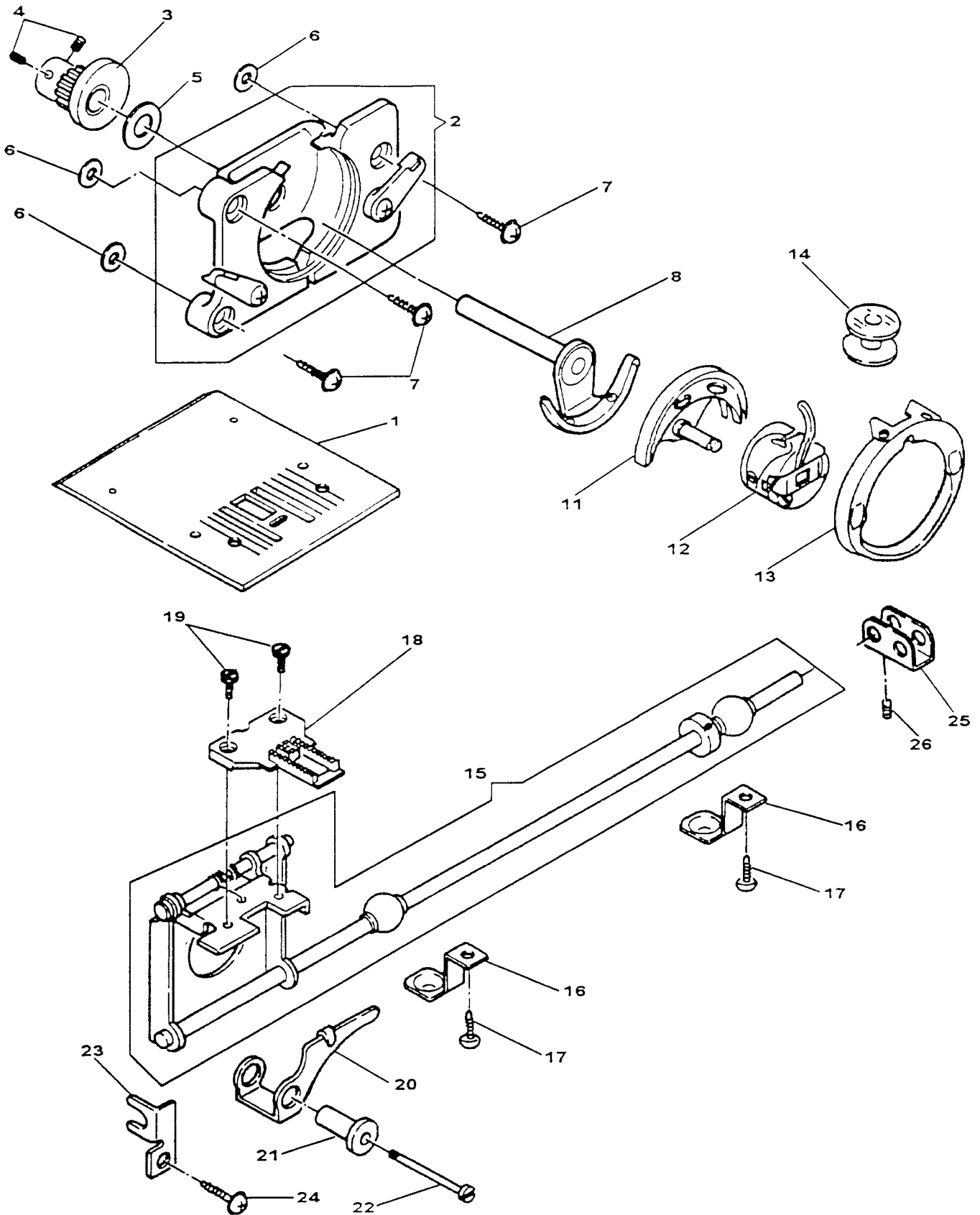

From the library of: Diamond Needle Corp

DEMAND RESPONSIVE NEEDLE TENSION SYSTEM

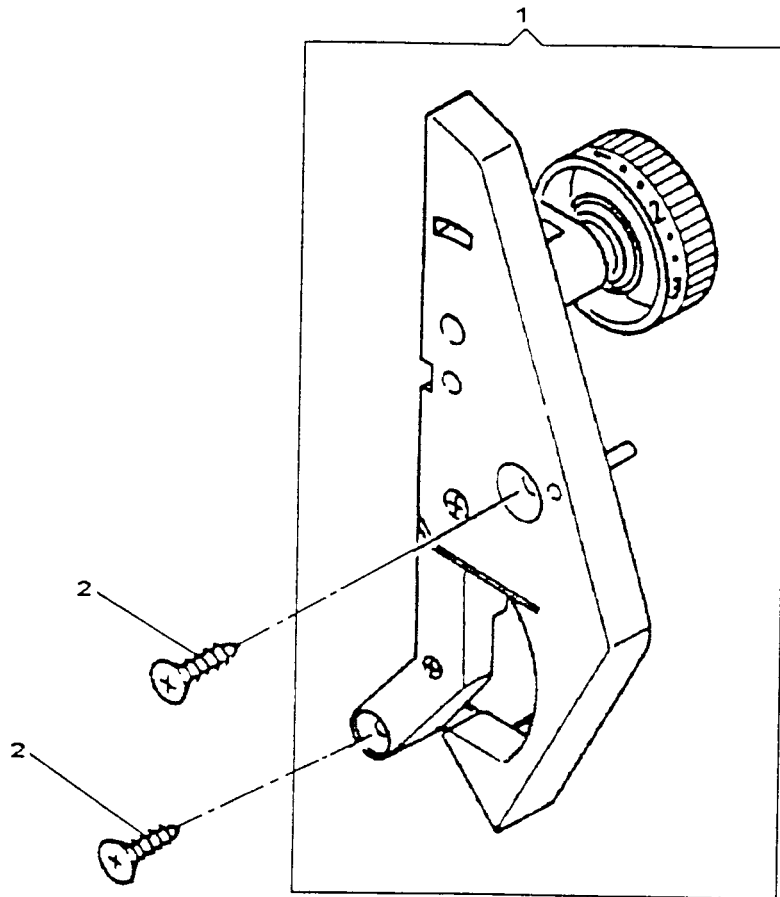

DEMAND RESPONSIVE NEEDLE TENSION SYSTEM
MODEL: 302/305/342/345

REF. PART NO. NO.	DESCRIPTION	3 3 3 3 0 0 4 4 2 5 2 5
1 316161-001	TENSION MODULE COMPLETE	X X
1 316161-002	TENSION MODULE COMPLETE	X X
2 113470-003	SCREW, TENSION MODULE	X X X X

PATTERN, STITCH LENGTH CONTROL & CAM CONTROLLED FEED
 MODEL: 302/305/342/345

REF. PART NO.	PART NO.	DESCRIPTION	3	3	3	3
			0	0	4	4
			2	5	2	5
1	316180-451	PATTERN SELECTOR DIAL		X		X
2	316237	DISC DRIVING GEAR SHAFT	X	X	X	X
3	445454	DISC FOLLOWER COMPLETE	X	X	X	X
4	445498	SPRING, DISC FOLLOWER	X	X	X	X
5	316207-006	DISC FOLLOWER RETAINING RING	X	X	X	X
6	316018	DISC FOLLOWER DISENGAGING SPRING		X		X
7	316276-002	CAM STACK COMPLETE		X		X
7	316270-001	CAM STACK COMPLETE	X			X
8	316285	DISC DRIVING GEAR SHAFT BRACKET ASSEMBLY	X	X	X	X
9	113455-003	SCREW, DISC DRIVING GEAR SHAFT BRACKET ASSEMBLY	X	X	X	X
10	316279-001	NEEDLE POSITION ASSEMBLY	X	X	X	X
11	316140	DISC FOLLOWER DISENGAGING LEVER		X		X
12	354826-451	SCREW, DISC FOLLOWER DISENGAGING LEVER		X		X
13	445338	DISC FOLLOWER DISENGAGING LEVER BUSHING		X		X
14	316313	NEEDLE BAR DRIVING ARM SLIDE	X	X	X	X
15	354642-451	SCREW, NEEDLE BAR DRIVING ARM SLIDE	X	X	X	X
16	445332	NEEDLE BAR DRIVING ARM SLIDE BRACKET ASSEMBLY	X	X	X	X
17	316064	HINGE STUDE, NEEDLE BAR DRIVING ARM SLIDE BRACKET	X	X	X	X
18	113455-004	NEEDLE POSITION LEVER BRACKET SET SCREW	X	X	X	X

PATTERN, STITCH LENGTH CONTROL & CAM CONTROLLED FEED

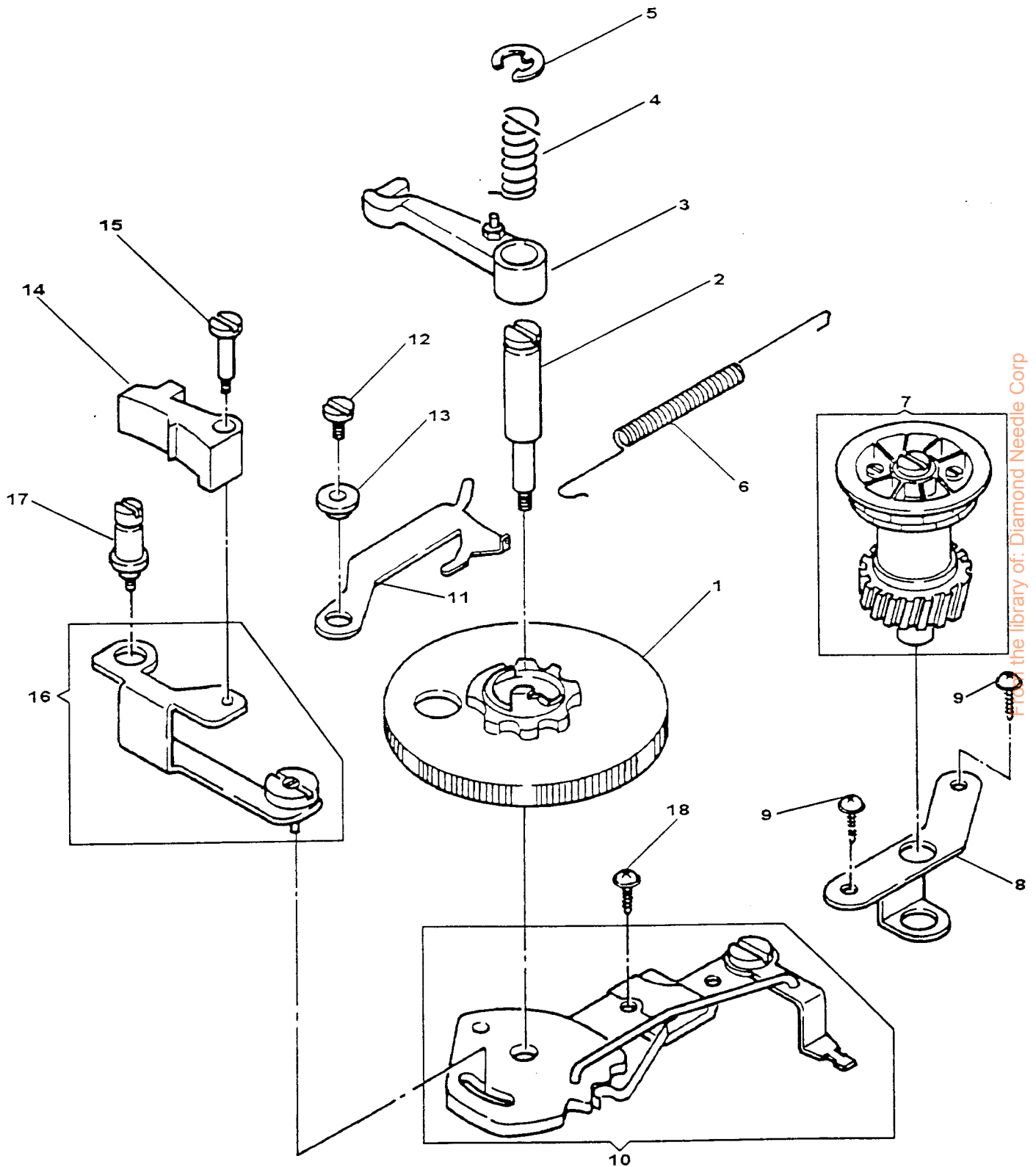

From the library of: Diamond Needle Corp

PATTERN, STITCH LENGTH CONTROL & CAM CONTROLLED FEED (CONT.)

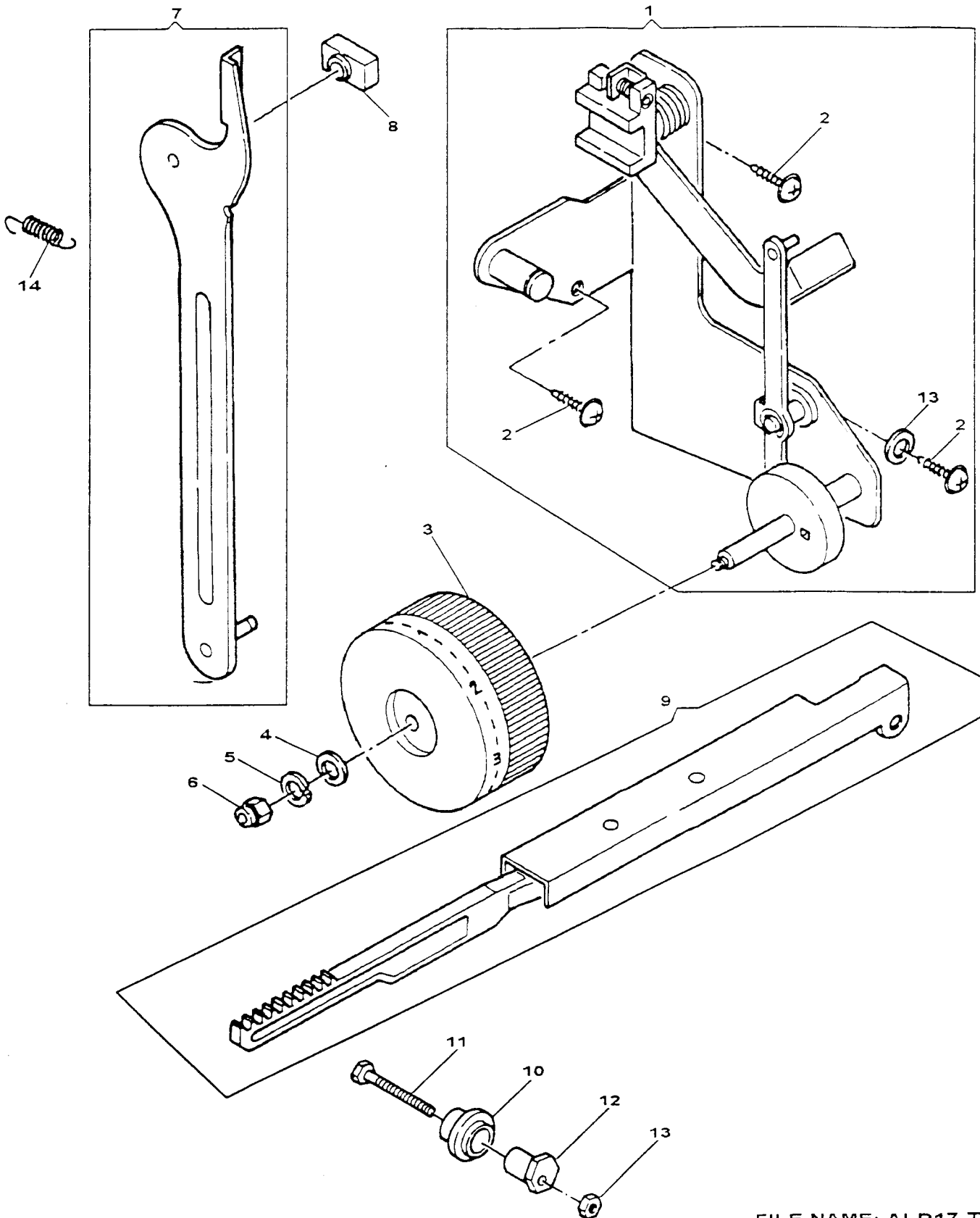

From the library of: Diamond Needle Corp

PATTERN, STITCH LENGTH CONTROL & CAM CONTROLLED FEED (CONT.)
 MODEL: 302/305/342/345

REF. NO.	PART NO.	DESCRIPTION	3	3	3	3
			3	3	3	3
			0	0	4	4
			2	5	2	5
1	316275-002	STITCH LENGTH CONTROL ASSEMBLY	X	X		
1	316275-001	STITCH LENGTH CONTROL ASSEMBLY			X	X
2	113455-004	SCREW, STITCH LENGTH & REVERSE MECH. MOUNTING PLATE	X	X	X	X
3	316096-451	STITCH LENGTH CONTROL DIAL			X	X
3	316096-452	STITCH LENGTH CONTROL DIAL	X	X		
4	316137-003	WASHER, STITCH LENGTH CONTROL DIAL	X	X	X	X
5	316069	STITCH LENGTH CONTROL DIAL RETAINING RING	X	X	X	X
6	314299-451	NUT, STITCH LENGTH CONTROL DIAL	X	X	X	X
7	316035	FEED FORKED CONNECTION ASSEMBLY	X	X	X	X
8	316353	FEED FORKED CONNECTION SLIDE BLOCK	X	X	X	X
9	316274	RACK CONNECTION ASSEMBLY	X	X	X	X
10	316040-002	RACK GUIDE PULLEY	X	X	X	X
11	316245-002	SCREW, RACK GUIDE PULLEY	X	X	X	X
12	316342	RACK GUIDE PULLEY ECCENTRIC BUSHING	X	X	X	X
13	53646	NUT, RACK GUIDE PULLEY	X	X	X	X
14	316341	SPRING. FORK CONNECTING	X	X	X	X

PATTERN, STITCH LENGTH CONTROL & CAM CONTROLLED FEED (CONT.)
 MODEL: 302/305/342/345

REF. PART NO.	DESCRIPTION	3	3	3	3
		0	0	4	4
		2	5	2	5
1	316159-001 BIGHT AMPLITUDE CONTROL LEVER ASSEMBLY	X	X	X	X
2	354543-001 SCREW, BIGHT AMPLITUDE CONTROL LEVER ASSEMBLY	X	X	X	X
3	444938 WASHER, BIGHT AMPLITUDE CONTROL LEVER ASSEMBLY SCREW	X	X	X	X
4	316181 NEEDLE BAR DRIVING ARM ASSEMBLY	X	X	X	X
5	316105-001 BIGHT MECHANISM MOUNTING BRACKET ASSEMBLY	X	X		
5	316105-002 BIGHT MECHANISM MOUNTING BRACKET ASSEMBLY			X	X
6	113455-003 SCREW, BIGHT MECHANISM MOUNTING BRACKET ASSEMBLY	X	X	X	X
7	316205 SPRING, NEEDLE BAR DIRVING ARM RETURNING	X	X	X	X

PATTERN, STITCH LENGTH CONTROL & CAM CONTROLLED FEED (CONT.)

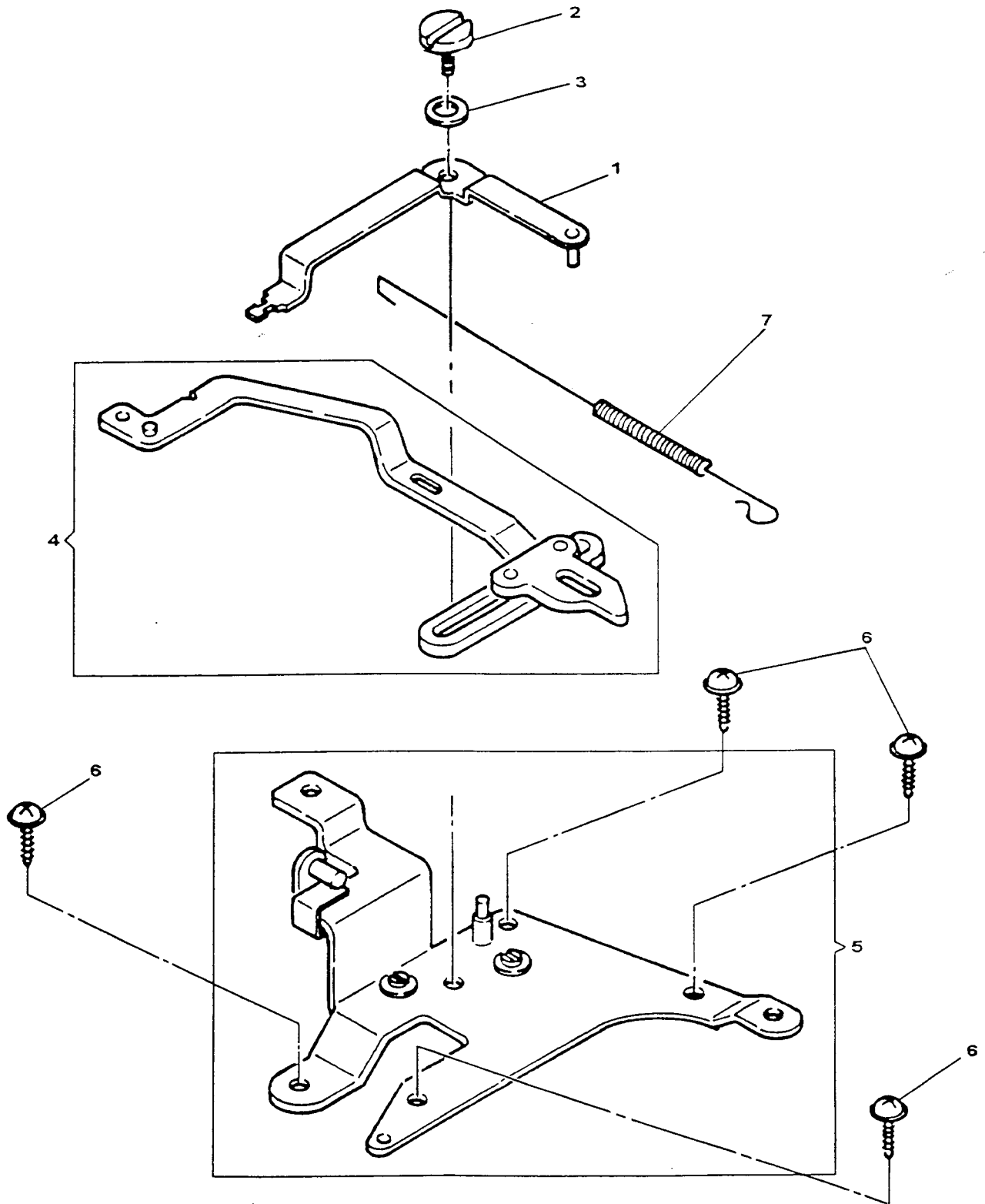

From the library of: Diamond Needle Corp

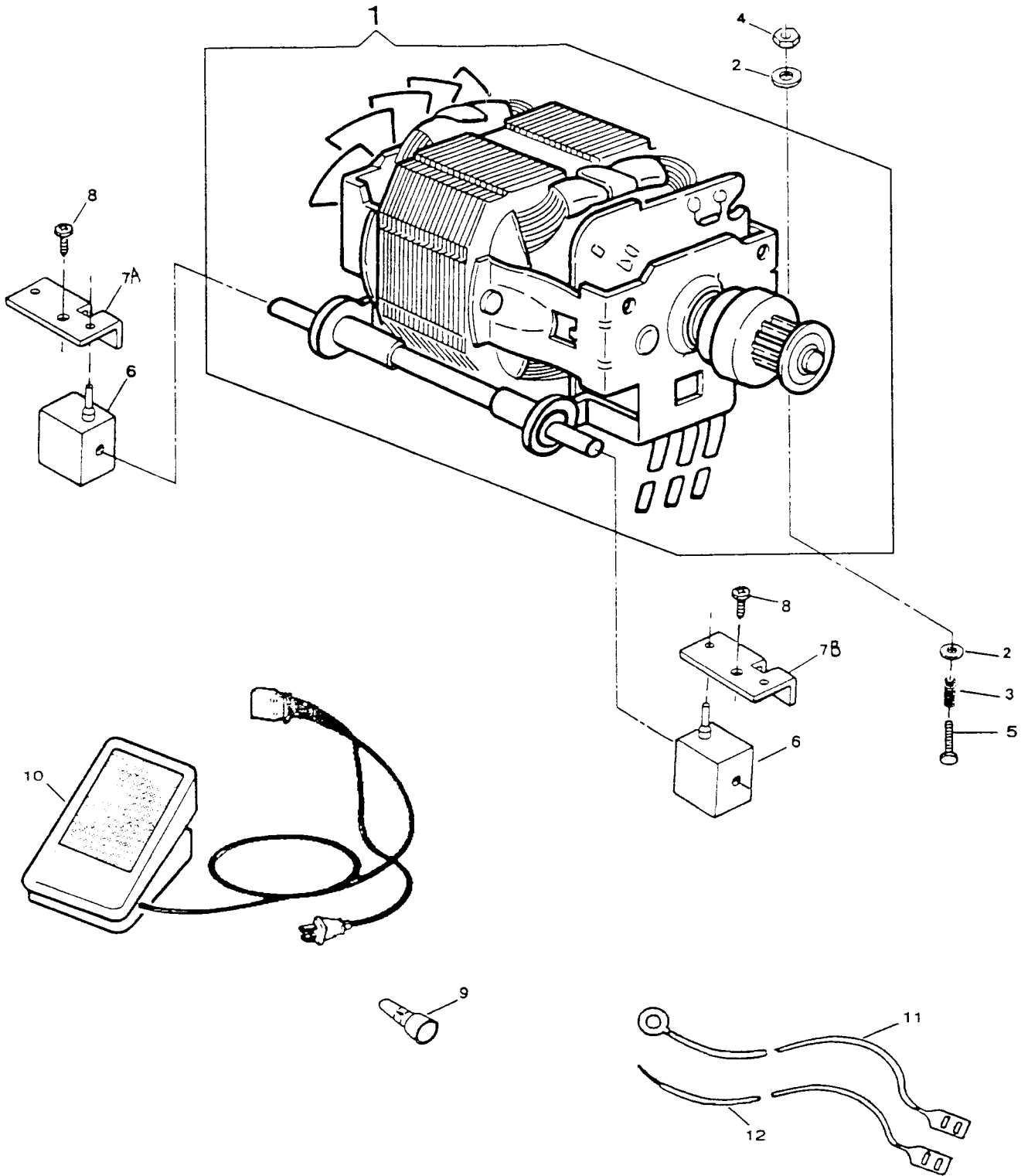

From the library of: Diamond Needle Corp

ELECTRICAL EQUIPMENT
MODEL: 302/305/342/345

REF. NO.	PART NO.	DESCRIPTION				
			3	3	3	3
			0	0	4	4
			2	5	2	5
1	317352-001	MOTOR COMPLETE (120V)	X	X	X	X
1	317427-007	MOTOR COMPLETE (230V, CE)	X	X	X	X
1	317436-002	MOTOR COMPLETE (240V)	X	X	X	X
2	37969	MOTOR ADJUSTING TENSION SCREW WASHER	X	X	X	X
3	314058	MOTOR ADJUSTING TENSION SPRING	X	X	X	X
4	53646	MOTOR ADJUSTING TENSION SCREW NUT	X	X	X	X
5	316245-001	MOTOR ADJUSTING STUD	X	X	X	X
6	979329-001	RESILIENT MOUNT	X	X	X	X
7A	316218	RESILIENT MOUNT CLIP	X	X	X	X
7B	988651-001	RESILIENT MOUNT CLIP	X	X	X	X
8	113455-003	RESILIENT MOUNT CLIP MOUNTING SCREW	X	X	X	X
9	317355	WIRE CONNECTOR	X	X	X	X
10	319003-003	FOOT CONTROLLER (TRIAC, 120V)	X	X	X	X
10	319003-007	FOOT CONTROLLER (240V)	X	X	X	X
10	319003-010	FOOT CONTROLLER (230V, CE)	X	X	X	X
10	319003-011	FOOT CONTROLLER (UK)	X	X	X	X
10	319003-012	FOOT CONTROLLER (AUSTRALIA)	X	X	X	X
11	317356-005	LEAD WITH TERMINAL	X	X	X	X
12	317356-006	LEAD WITH TERMINAL	X	X	X	X

ELECTRICAL EQUIPMENT (CONT.)
 MODEL: 302/305/342/345

REF. PART NO.	DESCRIPTION	3	3	3	3
		0	0	4	4
		2	5	2	5
1A 316271-001	LINT AND HEAT SHIELD ASSEMBLY	X	X	X	X
1B 316271-002	LINT AND HEAT SHILED ASSEMBLY (220-204V)	X	X	X	X
2A 317397-903	LIGHT ASSEMBLY (120V)	X	X	X	X
2B 137911-001	LIGHT ASSEMBLY (220-240V)	X	X	X	X
2B 317440-002	LIGHT ASSEMBLY (AUSTRALIA)	X	X	X	X
3 113455-004	SCREW, LINT AND HEAT SHIELD AND HEAD END MODULE	X	X	X	X
4 316244	FACE PLATE MOUNTING BRACKET	X	X	X	X
5 544211-051	SCREW, FACE PLATE MOUNTING BRACKET	X	X	X	X
6 194120-019	LIGHT BULB (120V)	X	X	X	X
6 194120-021	LIGHT BULB (240V)	X	X	X	X
7 540899	TY-WRAP SELF LOCKING	X	X	X	X
8 979585-207	POWER SWITCH	X	X	X	X
9 316217	RECEPTACLE HOLDER (120V)	X	X		
9 316219	RECEPTACLE HOLDER (230V)	X	X		
9 316220	RECEPTACLE HOLDER (120V)			X	X
9 316221	RECEPTACLE HOLDER (220-240V)			X	X

ELECTRICAL EQUIPMENT (CONT.)

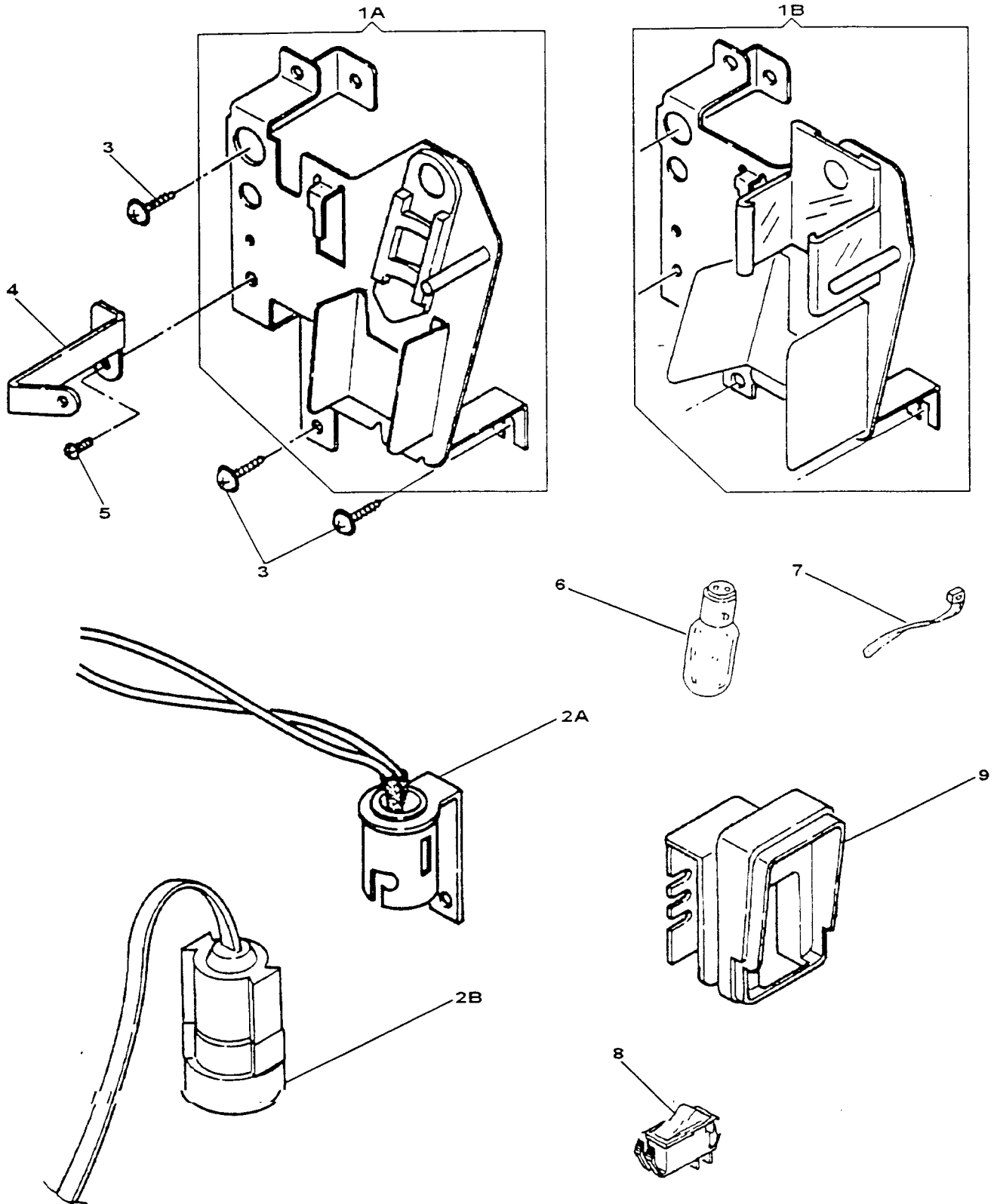

From the library of: Diamond Needle Corp

